





MULTI CYCLONE PLUS

A revolution in pool filtration



MultiCyclone Plus combines centrifugal and cartridge filtration into one streamline housing, creating an ultra compact filtration system that can be vertically installed on a pool pump.

-  **Dual stage filtration**
-  **Ultra compact**
-  **Ease of maintenance**
-  **Save time, water and energy**

MULTI  CYCLONE 12 PLUS

MULTI  CYCLONE 16 PLUS

Dual stage filtration

Incoming water tangentially enters its multiple hydrocyclones, generating a strong centrifugal effect. Approximately 80% of the incoming dirt load is spiralled down to its clear sediment chamber. The outgoing water is finally polished via its inbuilt cartridge filter, producing crystal clear water.

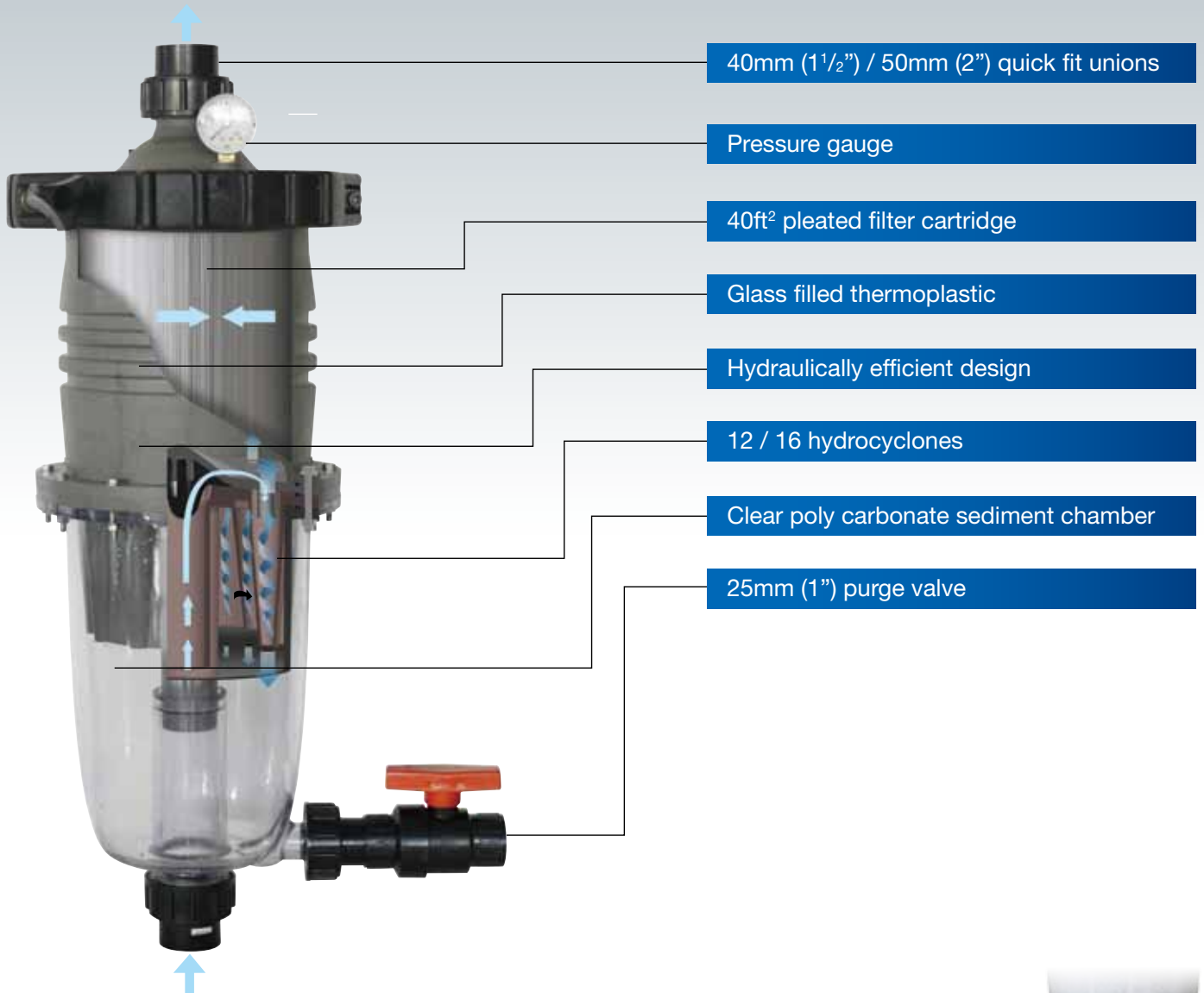

Extended filter capacity

As MultiCyclone Plus's centrifugal section filter pre-filters up to 80% of the incoming dirt load, the capacity of its 40 ft² filter cartridge is magnified by up to 5 times.

Ease of maintenance

MultiCyclone Plus's sediment chamber is easily cleaned by opening its purge valve. Only 15 litres of water is discharged.



Ultra compact

MultiCyclone Plus's streamlined design means the entire filtration system can be installed vertically, reducing the footprint of the equipment pad. Additionally, minimal pipework reduces the filtration system's overall head loss. Alternatively the MultiCyclone Plus can be installed next to the pump by using an optional support base.



Specifications

| Model | Hydrocyclones | Connection Ports | Minimum Flow | Maximum Flow | Filter Area | Maximum Pool Size | Maximum Pressure |
|----------------------------|---------------|------------------|--------------|--------------|-----------------------------|-------------------|------------------|
| MultiCyclone12 Plus | 12 | 40mm / 1 1/2" | 40lpm | 152lpm | 3.7m ² / 40 sqft | 73,000l | 350 kPa (50psi) |
| MultiCyclone16 Plus | 16 | 50mm / 2" | 50lpm | 152lpm | 3.7m ² / 40 sqft | 73,000l | 350 kPa (50psi) |

Maximum flow is limited by the surface area of the filter cartridge. Residential Cartridge Design Filtration Rate: 41 lpm/m² (1gpm/ft²)

Dimensions

MultiCyclone 12 Plus

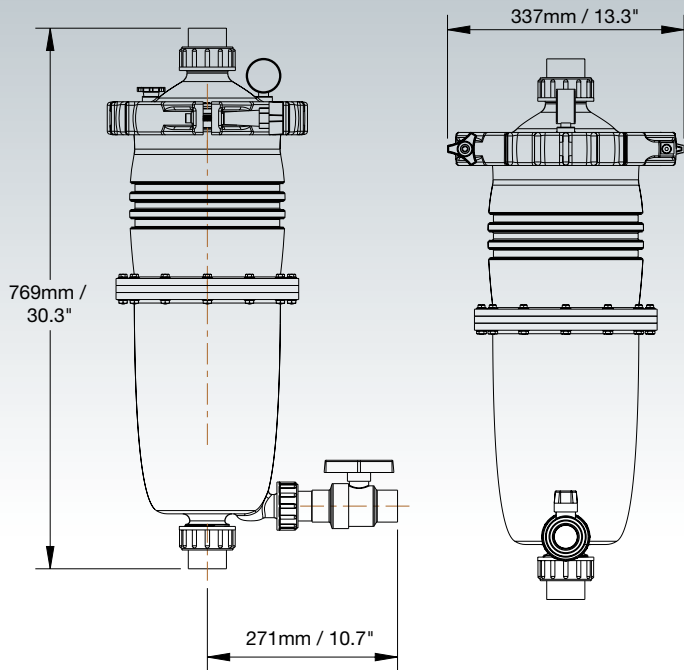

MultiCyclone 16 Plus

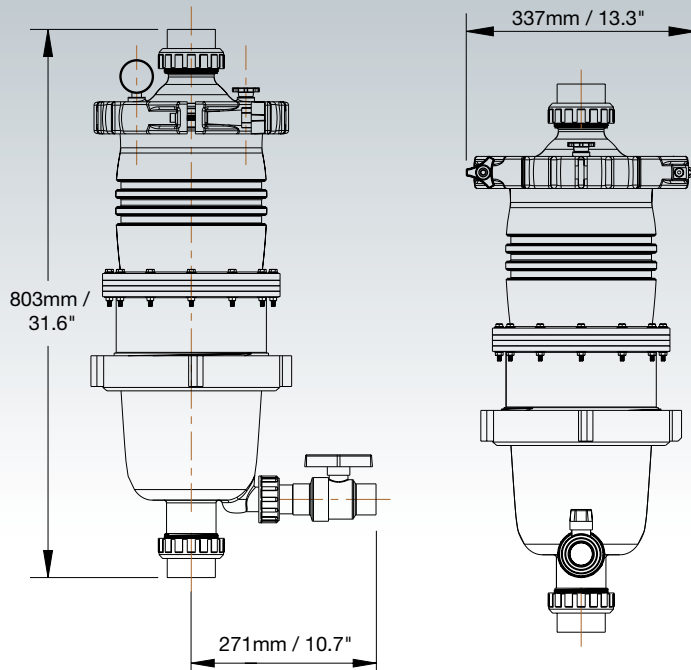

Head Loss Curves

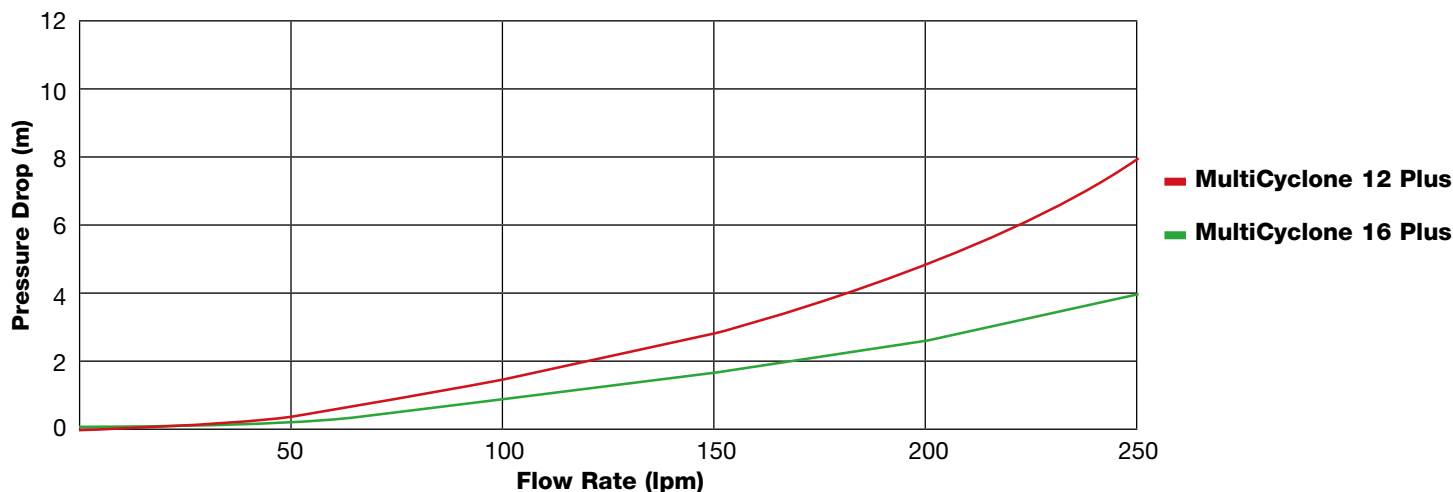

Warranty

MultiCyclone Plus is covered by a 2 year warranty and 1 year warranty on labour. Commercial installations are covered by a 1 year warranty.

OFFICES - AUSTRALIA

NSW - Sydney (Head Office)
Tel: +61 2 9898 8600
QLD - Brisbane
Tel: +61 7 3299 9900
VIC/TAS - Melbourne
Tel: +61 3 9764 1211
WA - Perth
Tel: +61 8 9273 1900
SA/NT - Adelaide
Tel: +61 8 8244 6000
ACT Distribution
Tel: +61 2 6280 6476

OFFICES - OVERSEAS

Waterco (Europe) Limited
Sittingbourne, Kent, UK
Tel: +44 (0) 1795 521 733
Waterco (USA) Inc
Augusta, Georgia, USA
Tel: +1 706 793 7291
Waterco Canada
St Hyacinthe, Quebec, Canada
Tel: +1 450 796 1421
Waterco (NZ) Limited
Auckland, New Zealand
Tel: +64 9 525 7570

Waterco (C) Limited
Guangzhou, China
Tel: +86 20 3222 2180
Waterco (Far East) Sdn Bhd
Selangor, Malaysia
Tel: +60 3 6145 6000
PT Waterco Indonesia
Jakarta, Indonesia
Tel: +62 21 4585 1481
Waterco Singapore Intl Pte Ltd
Nehsons Building, Singapore
Tel: +65 6344 2378

DISTRIBUTED BY:

WATERCO
water, the liquid of life

