

ProPulse Series Universal Turbine Flow Meter

Plug & Play...No Programming Required

ProPulse provides superior performance and delivers accurate **Ultra Low Flow** measurement that is highly repeatable under the most demanding of industrial environments. The ProPulse 300 Series consists of one universal body that can be customized into five (5) selectable flow ranges. Changing from one flow range to another is simply achieved by inserting a very precise flow jet... No special tools required...a change out is simple...truly Plug and Play

M12 Connector

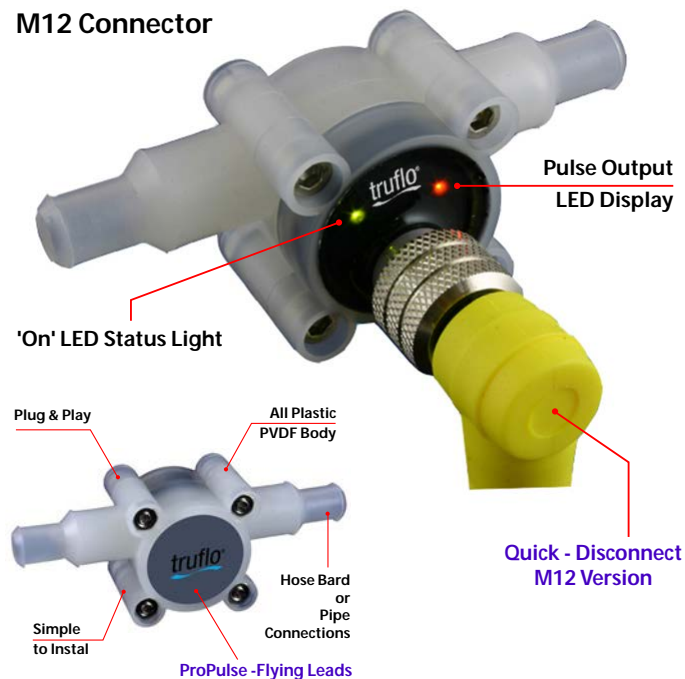

Features

- Universal Body 5 Different Flow Ranges - (Flow Jets Are Field Replaceable)
- Excellent Chemical Resistance
- All Plastic PVDF Body, Rotor, Sapphire Bearings
- Ultra Low Flow Ranges from 50 ml/min (.013 GPM)
- Pressure Rating 10 bar (150 psi)
- Compact - Light weight
- Temperature Rating -40 -120°C (-40 -248°F)
- Barbed Hose intal/Outlet connection 5/16 and 1/2 inch. 8mm, 12mm, or 3/8" Pipe Connector
- High Accuracy & Repeatability
- NPN Pulse Output

Technical Specifications

Accuracy	±1% Full Scale
Repeatability	±0.1%
Pulse Output	NPN, Hall Effect Square Wave – Switch Current 10 mA max.
Pressure rating	Bar (150 Psi)
Viscosity / particles	Less than 90 micron
Temperature rating	-20°C - 125°C (-4 -240°F)
Calibration	6.8 GHZ
Body and internals	PVDF, Sapphire
Seals	Viton O-ring
Connections	Barbed 8 and 12 mm (5/16 and 1/2 inch) or 3/8" straight pipe
Power Consumption	7.5 mA

The ProPulse operates using a PVDF rotor with encapsulated magnetic inserts which rotate on a long wearing set of sapphire bearings designed to provide years of reliability.

As the rotor spins the magnetic field produced by the inserts is pick up by a Hall Effect Sensor which converts the rotation into a square wave NPN pulse output that can be sent directly to a metering pump or display.

ProPulse Series Flowmeter

At the heart of the meter is a precision turbine that rotates freely on robust sapphire bearings and contains chemically resistant ceramic magnets that are detected through the chamber wall by a Hall effect detector. The output is a stream of NPN pulses that are readily interfaced with most electronic display or recording devices. This combination of materials and technology ensures a long life product with reliable operation throughout.

Standard Materials of Construction

Body and cap - PVDF

'O' Ring seal - Viton™

Magnets - Ceramic

Bearings - Sapphire

Electrical Connections

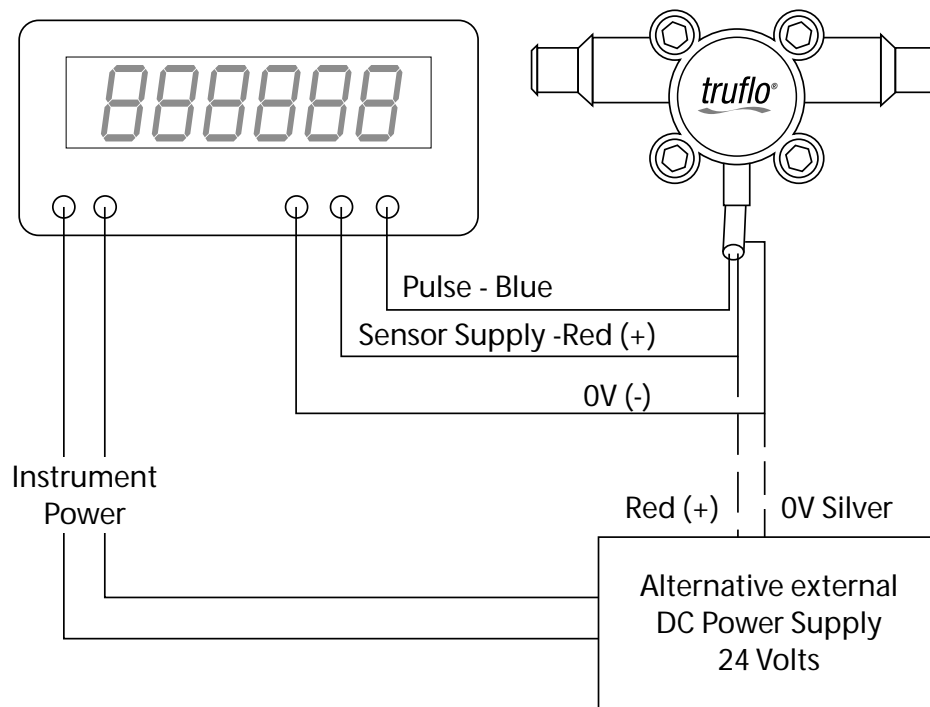

Flow Ranges and Pulses

Model	Range Liter/min	Range GPM	Accuracy \pm % Full Scale	Frequency Hz	K-factor 1/liter	K-factor 1/gallon
300	0.05 - 0.50	0.013 - 0.132	2.0	142	17000	64352
304	0.12 - 1.50	0.032 - 0.396	2.0	175	7000	26498
308	0.20 - 4.50	0.053 - 1.189	1.5	260	3500	13249
312	0.25 - 6.50	0.066 - 1.717	1.5	230	2100	7949
316	0.30 - 10.0	0.079 - 2.642	1.0	235	1420	5375
420	0.50 - 15.0	0.132 - 3.963	1.0	245	980	3710

Pressure Drop Curve

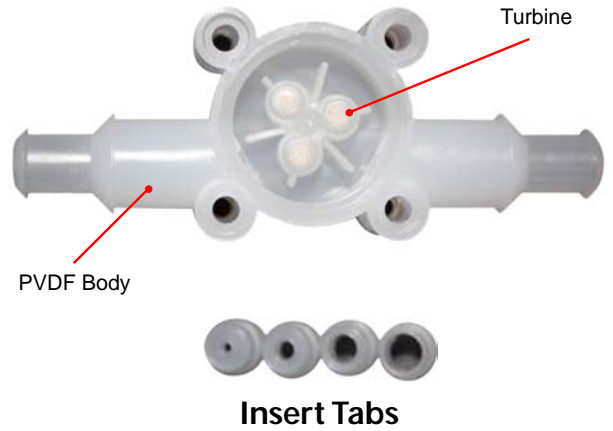
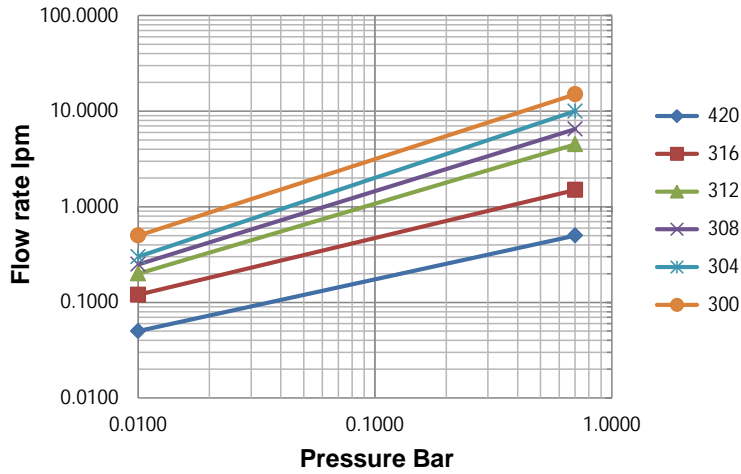

Dimensions

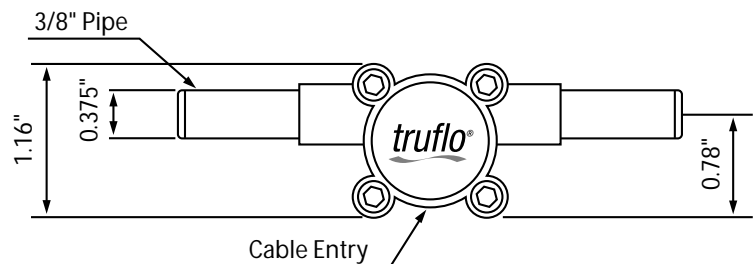
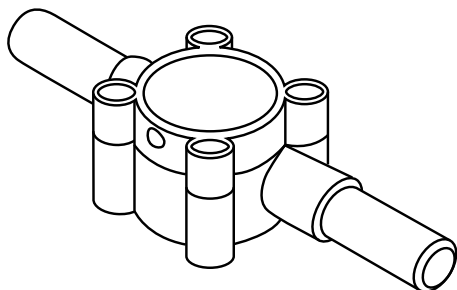
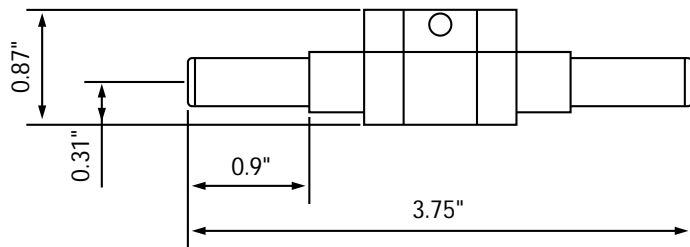
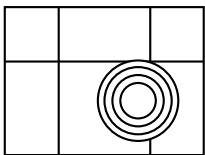

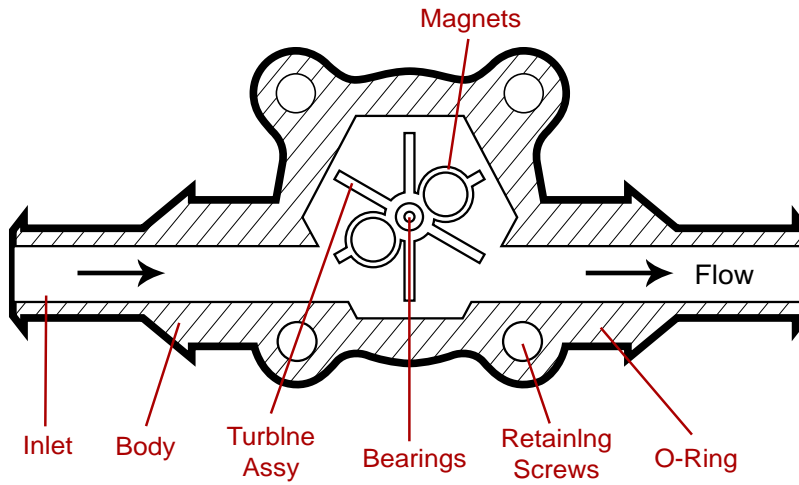

Model Numbering System

Ex **304** - **V** - **O** - **P** - **O** - **O**

Range	Code
.05 to 0.5 lpm	300
.12 to 1.5 lpm	304
.2 to 4.5 lpm	308
.25 to 6.5 lpm	312
.3 to 10.0 lpm	316
.5 to 15.0 lpm	420

O-ring	Code
Viton™	V

Connections	Code
5/16"-1/2" 8 / 12 mm Hose Barb	O
3/8" Straight Pipe	J

Body Material	Code
PVDF (standard)	P

Calibration	Code
Standard	O

Display	Code
No Display	O
M12 LED	1